

HM-8180

Lockstitch button holer



	Use
-2	Buttonholes for clothing such as dress shirts, blouses, work clothes and women's clothes
-3	Buttonholes for knitted garments such as knitted underwear, sweaters and jerseys.
-4	Buttonholes for stretch materials such as knitted wear and cardigans
-5	Buttonholes for clothing such as work clothes and women's clothes. Belt holes for child seats, etc.

Sub-class	-2	-3	-4	-5
Max. sewing speed	3,600 rpm		3,200 rpm	2,800 rpm
No. of stitches per buttonhole	60 - 360		147 - 360	60 - 360
Feed mechanism	Upper and lower feed			Upper feed
Buttonhole length	9.5 - 32 mm		9.5 - 32 mm	32 - 48 mm
Buttonhole width	2 - 6 mm			
Max. sewing thickness	4 mm	3.5 mm	6 mm	5 mm
Work clamp height	13 mm	12.5 mm	13 mm	12 mm
Needle bar stroke	36.5 mm			
Needle DP X 5	# 14	# 11	# 14	
Lubrication	Automatic			
Tape winder	Option			
Ruler	Option			
Gimp guide			Standard equipment	

From the library of: Diamond Needle Corp

Accessories

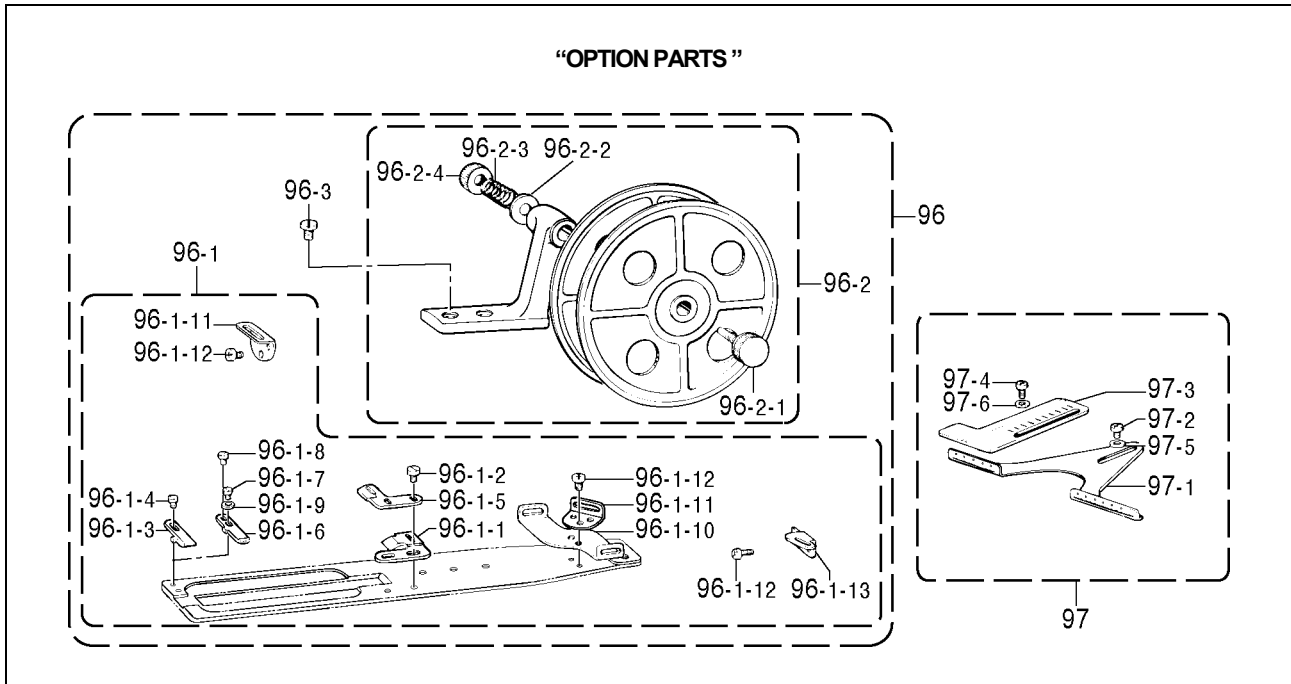

Ref. No.	Part name	Part code	Q'ty
	<OPTION PARTS>		
96	Tape guard winder assy	S25672009	1
96-1	Tape guard assy	S25671001	1
96-1-1	Tape guard, B	144998001	1
96-1-2	Screw, SM 2.38	105288002	2
96-1-3	Tape guard F	144997001	1
96-1-4	Screw, SM 2.38	122771051	2
96-1-5	Tape guide, C	144999001	1
96-1-6	Tape guard, F	144628001	1
96-1-7	Screw, SM 2.38	122771051	1
96-1-8	Screw, SM 2.38	105970001	1
96-1-9	Collar	110067001	1
96-1-10	Tape guide, lower	143749001	1
96-1-11	Tape guide, upper	143748001	2
96-1-12	Screw, PAN SM 3.18-40x4	062660412	6
96-1-13	Tape guide	145441001	1
96-2	Tape winder assy	143767102	1
96-2-1	Screw	143980001	1
96-2-2	Washer	108494001	1
96-2-3	Spring, compression	108495001	1
96-2-4	Nut, tension	100136001	1
96-3	Screw, SM 4.37x9	107407003	2
97	Ruller assy	S31893001	1
97-1	Ruller	141705001	1
97-2	Screw, PAN SM 4.37-40x5	062680512	2
97-3	Ruller	147156001	1
97-4	Screw, PAN SM 4.37-40x5	062680512	2
97-5	Washer	116662003	2
97-6	Washer, PLAIN M 4.37	025680232	2

Different part list

Part name	Q'ty	Subclass			
		-2	-3	-4	-5
Needle DPX5	4	107415014 (#14)	107415011 (#11)	107415014 (#14)	←
Cutter, 5/8	1	107205001	←	←	-----
Cutter, 3/8	1	109837001	←	←	-----
Cutter, 3/4	1	107207001	←	←	-----
Cutter, 1	1	107210001	←	←	-----
Cutter, 48	2	-----	-----	-----	147941001
Change gear, 28	1	-----	-----	-----	141375000
Change gear, 48	1	-----	-----	-----	141385000
Change gear, 30	1	141376000	←	-----	141376000
Change gear, 46	1	141384000	←	-----	141384000
Change gear, 34	1	-----	141378000	-----	141378000
Change gear, 42	1	-----	141382000	-----	141382000
Change gear, 32	1	-----	-----	141377000	-----
Change gear, 44	1	-----	-----	141383000	-----
Change gear, 38	2	141380000	-----	141380000	-----
Change gear, 36	1	141379000	←	←	-----
Change gear, 40	1	141381000	←	←	-----

Motor pulley and V-belt selection

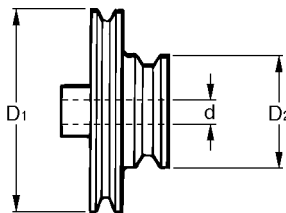

Machine Speed (rpm)	Frequency	Motor pulley			High speed V-belt		Low speed V-belt	
		Outside diameter	Core	Parts code	Mark	Parts code	Mark	Parts code
3,600	50Hz	D1=187.5 D2=79	d=14	S33007-002 *	M44	S18707-144	M41	S18707-141
			d=15.88	S33008-002 *				
	60Hz	D1=152.8 D2=56	d=14	S31131-002	M42	S18707-142	M40	S18707-140
3,200	50Hz	D1=160 D2=81	d=14	141707-002	M43	S18707-143	M42	S18707-142
			d=15.88	145781-002				
	60Hz	D1=134.2 D2=69.5	d=14	141709-002	M41	S18707-141	M41	S18707-141
3,000	50Hz	D1=152.8 D2=73.4	d=14	S42051-002	M42	S18707-142	M41	S18707-141
			d=15.88	S42052-002				
	60Hz	D1=127.6 D2=62.2	d=14	S33254-002	M40	S18707-140	M40	S18707-140
2,800	50Hz	D1=134.2 D2=69.5	d=14	141709-002	M41	S18707-141	M41	S18707-141
			d=15.88	145780-002				
	60Hz	D1=119.5 D2=69.5	d=14	143890-002	M41	S18707-141	M40	S18707-140
			d=15.88	145782-002				
			d=19.05	159831-002				

*For 3,200 rpm in 50 Hz areas, use the washer plain 8 (S34803-001).

*For 3,600 rpm in 50Hz areas, use the motor spacer set (S33043-001).

Gauge parts List

Change gear

Number of stitches	Change gear (Left-side)		Change gear (Right -side)		Number of stitches	Change gear (Left-side)		Change gear (Right-side)	
	Mark	Parts code	Mark	Parts code		Mark	Parts code	Mark	Parts code
360	54	141388-000	22	141372-001	133	36	141379-000	40	141381-000
319	52	141387-000	24	141373-001	126	35	S09394-000	41	S09395-000
283	50	141386-000	26	141374-000	119	34	141378-000	42	141382-000
252	48	141385-000	28	141375-000	107	32	141377-000	44	141383-000
226	46	141384-000	30	141376-000	96	30	141376-000	46	141384-000
203	44	141383-000	32	141377-000	86	28	141375-000	48	141385-000
182	42	141382-000	34	141378-000	77	26	141374-000	50	141386-000
164	40	141381-000	36	141379-000	68	24	141373-001	52	141387-000
147	38	141380-000	38	141380-000	60	22	141372-001	54	141388-000

Gauge parts List

Cutter

<p>109837-001</p> <p>3/8</p>	<p>107204-001</p> <p>7/16</p>	<p>107200-001</p> <p>1/2</p>	<p>S03278-001</p> <p>9/16</p>	<p>107205-001</p> <p>5/8</p>	<p>S25641-001</p> <p>11/16</p>
<p>107207-001</p> <p>3/4</p>	<p>S25642-001</p> <p>13/16</p>	<p>109838-001</p> <p>7/8</p>	<p>107210-001</p> <p>1</p>	<p>151837-001</p> <p>3/8</p>	<p>151838-001</p> <p>7/16</p>
<p>151839-001</p> <p>1/2</p>	<p>S03279-001</p> <p>9/16</p>	<p>151840-001</p> <p>5/8</p>	<p>151841-001</p> <p>3/4</p>	<p>153340-001</p> <p>7/8</p>	<p>159722-001</p> <p>1</p>
<p>S30294-001</p> <p>29</p>		<p>143780-001</p> <p>32</p>		<p>147987-001</p> <p>45</p>	
<p>147941-001</p> <p>48</p>		<p>147233-001</p> <p>50</p>			



Gauge parts List

*1 Work clamp assy, W / F-G

*2 Work clamp assy

*3 Finger guard

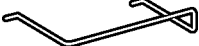
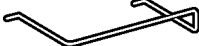
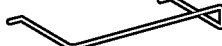
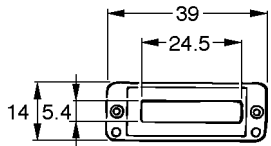
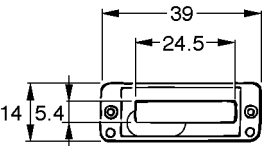
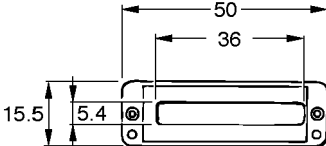
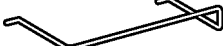
*4 Work clamp

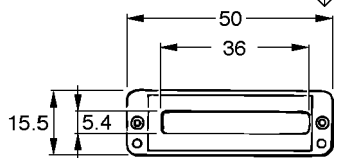
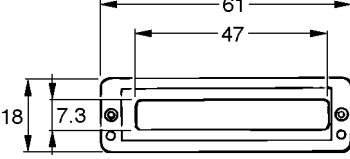
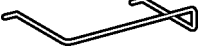
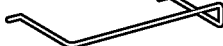
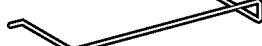
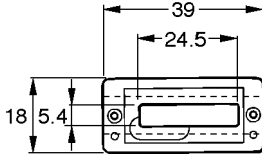
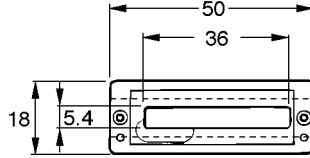
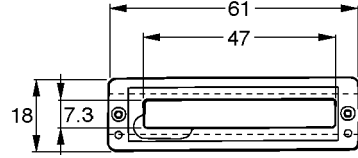
< For "2" >		
*1 S37125-001 (16mm)	*1 S37124-001 (16mm)	*1 S37117-001 (25mm)
*2 150763-001 (16mm)	*2 147112-001 (16mm)	*2 150764-001 (25mm)
*3 150561-000	*3 150561-000	*3 150562-000
*4 145146-001 (With Rubber)	*4 147113-001	*4 144498-001 (With Rubber)
*3 	*3 	*3 
*4 	*4 	*4 
< For "2" >		
*1 S37127-001 (25mm)	*1 S37118-001 (32mm)	
*2 144493-001 (25mm)	*2 150765-001 (32mm)	
*3 150562-000	*3 150563-000	
*4 144494-001	*4 144575-001 (With Rubber)	
*3 	*3 	
*4 	*4 	
< For "2" >		
*1 S58308-001 (16mm)	*1 S58309-001 (25mm)	*1 S58310-001 (32mm)
*2 S35762-001 (16mm)	*2 S35763-001 (25mm)	*2 S35764-001 (32mm)
*3 150561-000	*3 150562-000	*3 150563-000
*4 159761-001(With Rubber)	*4 159762-001(With Rubber)	*4 159763-001(With Rubber)
*3 	*3 	*3 
*4 	*4 	*4 



Gauge parts List

*1 Work clamp assy, W / F-G

*2 Work clamp assy

*3 Finger guard

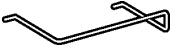
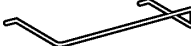
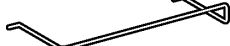
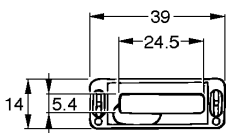
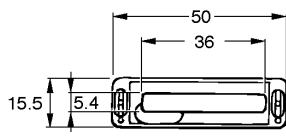
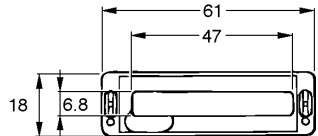
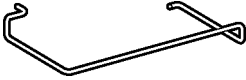
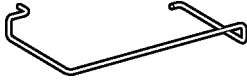
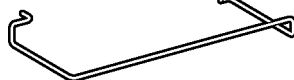
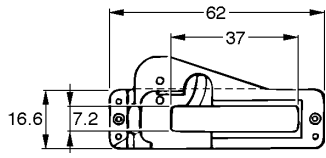
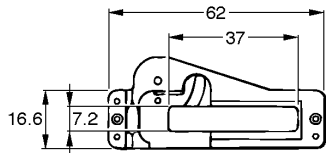
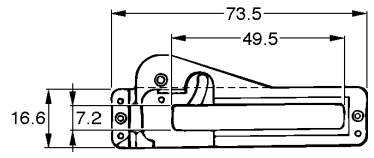
*4 Work clamp

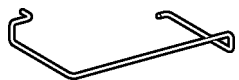
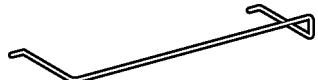
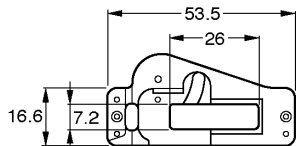
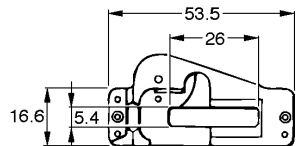
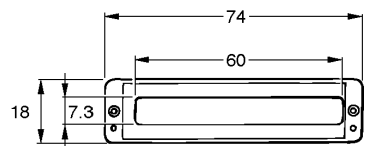
< For "3" >		
*1 S37126-001 (16mm)	*1 S37119-001 (25mm)	*1 S37120-001 (32mm)
*2 150767-001 (16mm)	*2 150768-001 (25mm)	*2 150769-001 (32mm)
*3 150561-000	*3 150562-000	*3 150563-000
*4 145136-001 (With Rubber)	*4 144630-001 (With Rubber)	*4 144632-001 (With Rubber)
*3 	*3 	*3 
*4 	*4 	*4 
< For "4" >		
*1 S37121-001 (25mm)	*1 S37128-001 (25mm)	*1 S37122-001 (32mm)
*2 150770-001 (25mm)	*2 147719-001 (25mm)	*2 150771-001 (32mm)
*3 150566-000	*3 150566-000	*3 150567-000
*4 145362-001	*4 147720-001 (With Rubber)	*4 145375-001
*3 	*3 	*3 
*4 	*4 	*4 
< For "4" >	< For "4" > Light-weight materials	< For "5" >
*1 S37129-001 (16mm)	*1 S37130-001 (16mm)	*1 S37123-001 (50mm)
*2 147721-001 (16mm)	*2 151610-101 (16mm)	*2 150766-001 (50mm)
*3 150565-000	*3 150565-000	*3 150564-000
*4 147722-001(With Rubber)	*4 151611-001	*4 147230-001
*3 	*3 	*3 
*4 	*4 	*4 

Gauge parts List

*1 Needle plate assy

*2 Base plate assy

*3 Needle

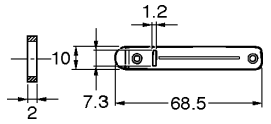
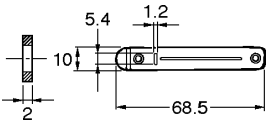
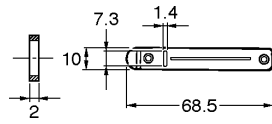
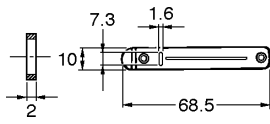
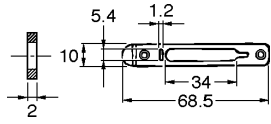
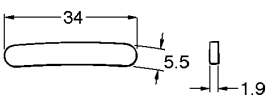
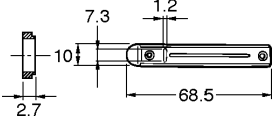
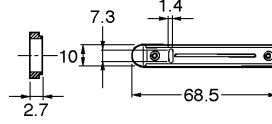
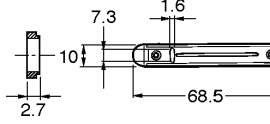
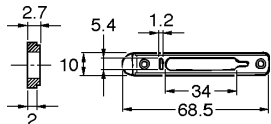
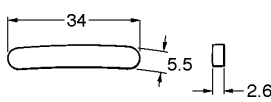
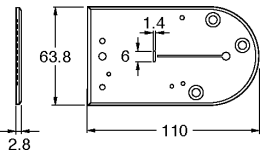
< For "2, 4" >			
*1 S58281-001	*1 S58282-001	*1 S58283-001	*1 S58284-001
*2 S58306-001	*2 S58306-001	*2 S58306-001	*2 S58306-001
*3 147313-001	*3 151613-001	*3 145246-001	*3 147315-001
*3 	*3 	*3 	*3 
< For "2, 4" >			
*1 S58285-001	*1 S58286-001	*1 S58287-001	*1 S58288-001
*2 S58306-001	*2 S58306-001	*2 S58306-001	*2 S58306-001
*3 151842-001	*3 S35759-001	*3 S35760-001	*3 S35761-001
*3  Plastic plate 151843-001 	*3 	*3 	*3 
< For "2, 4" >			
*1 S58289-001	*1 S58294-001		
*2 S58306-001	*2 None		
*3 S35993-001	*3 S56408-001		
*3  Plastic plate S01270-001 	*3 		

Gauge parts List

*1 Needle plate assy

*2 Base plate assy

*3 Needle

< For "3" >			
*1 S58290-001	*1 S58291-001	*1 S58292-001	*1 S58293-001
*2 S58307-001	*2 S58307-001	*2 S58307-001	*2 S58307-001
*3 144635-001	*3 144637-001	*3 144639-001	*3 156611-001
<p>*3</p>	<p>*3</p>	<p>*3</p>	<p>*3</p> <p>Plastic plate 151843-001</p>
< For "5" >			
None			
None			
*3 S56407-001			
<p>*3</p>			

*2 Base plate assy

< For "2,4" >	< For "3" >
S58306-001	S58307-001